

109037XX FREE FALL FIRE VALVE MKII

Free Fall Fire Valves are an essential part of fire protection systems. They have been specifically designed for generators & plant rooms. The valves may be used for either cut-off or dump applications in order to isolate or dump the fuel supply. Activated by the melting of a fusible link or connected to optional ancillary items such as tilt position switch, manual quick release / panic buttons, SQR (electrical) intervention with main fire alarm / BMS communication.

The free-fall linkage allows the weight to start to fall before it is required to move the valve lever, this makes sure that the weight achieves sufficient momentum for reliable operation. The lubricated plug valve design, selected for reliable operation, can be easily maintained compared to ball valves

Technical Specification

Material	See Illustration
Finish	RAL3020 Red
Maximum Pressure	14 Bar (200psi)
Standard Cable	9m
Fusible Link	72°C as standard
Maintenance Reqd.	Test, lubricate and Record 3 times/year
Valve Rotation	90° (¼ turn)
Lubricant	99013852
Flange Spec	BS4504, PN16
Screwed Spec	BSP parallel

Dimensions (not to scale)

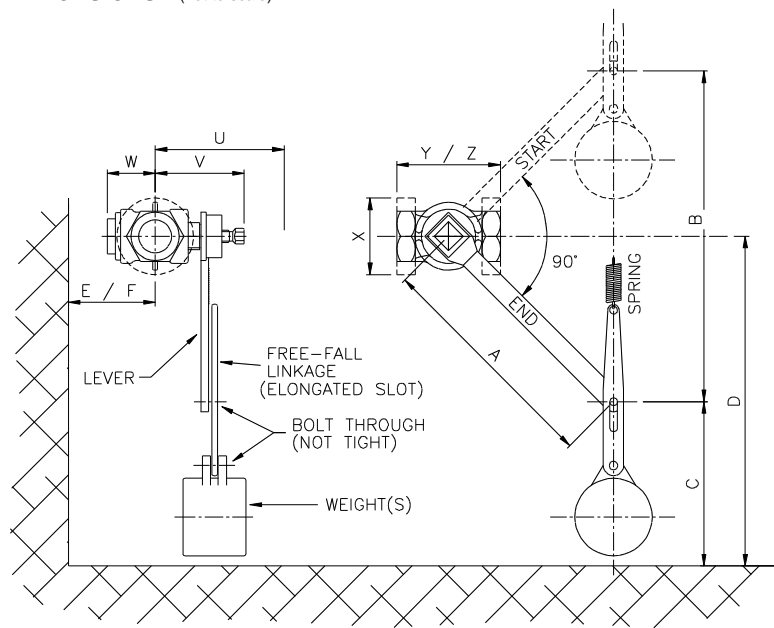

Important dimensions

- E Min dist. to remove plug with valve in-line
- F Min dist. to wall
- U Clearance to remove lubricating screw
- X Flange diameter
- Y Length of screwed valve
- Z Length of flanged valve

Kit Part Number	Valve Size	Connection	Z	Y	X	W	V	U	A	B	C	D	E	F	Weight	Kit Weight
10903701H	½"	BSP	—	95	45	65	90	100	270	380	178	368	152	51	1x 2.3Kg	6 kg
10903705H	¾"	BSP	—	95	45	65	90	100	270	380	178	368	165	58	1x 2.3Kg	6 kg
10903709H	1"	BSP	—	108	55	65	90	100	270	380	178	368	191	64	1x 2.3Kg	6 kg
10903710H	1"	Flanged	141	—	110	65	90	100	270	380	178	368	191	64	1x 2.3Kg	6 Kg
10903713H	1¼"	BSP	—	127	65	80	105	115	308	434	178	395	229	76	1x 2.3Kg	7Kg
10903717H	1½"	BSP	—	127	70	80	105	115	308	434	195	412	254	76	1x 4.5KG	10kg
10903721H	2"	BSP	—	150	90	85	105	115	308	434	229	446	330	102	1x 6.8Kg	15kg
10903722H	2"	Flanged	178	—	150	85	120	130	308	434	229	446	330	102	1x 6.8Kg	15kg
10903725H	2½"	BSP	—	172	197	106	140	150	783	1106	229	782	330	102	1x 6.8Kg	24Kg
10903726H	2½"	Flanged	190	—	197	106	140	150	783	1106	229	782	330	102	1x 6.8Kg	24Kg
10903729H	3"	BSP	—	195	184	125	170	180	783	1106	229	782	457	152	1x 6.8Kg	32Kg
10903730H	3"	Flanged	203	—	184	125	170	180	783	1106	251	804	457	152	1x 6.8Kg	32Kg
10903734H	4"†	Flanged	228	—	216	153	200	210	630	990	251	746	470	165	2x 6.8Kg	53Kg
10903740H	6"†	Flanged	267	—	279	203	243	253	751	1062	276	807	660	203	4x 6.8Kg	96Kg

† 4" and 6" valves are only available in flanged versions.

109037XX FREE FALL FIRE VALVE MKII

INSTALLATION

The valve may be installed in either horizontal or vertical pipe providing it is oriented such that the plug is parallel to the ground. Ensure that any pipe expansion or miss-alignment will not distort the valve body as this will cause additional valve friction.

Fit the lever onto the square valve shaft and tighten the fixing screw. Make sure that the lever travels freely from 45° up to 45° down.

Attach the free-fall linkage and weight(s) to the lever using the supplied nuts and bolts as shown in the diagrams. If using a 4", 5" or 6" valve, multiple weights and the pulley arrangement must be used as shown below. DO NOT tighten the bolt through the lever and free-fall link too tight as the free-fall link MUST be able to slide freely.

Finally fit the spring and cable to the top of the free-fall link. The cable should run vertically from the spring to the first pulley. The cable should then pass over any anticipated fire hazards with fusible link(s) installed in the cable 0.3 to 1.0m above the hazard. The cable may then be routed to a manual quick release (MQR) by the exit or terminated at a wall anchor by means of crimping. The system can also be incorporated with a solenoid quick release device (SQR) that allows for remote emergency activation electrically.

Note: When using a manual quick release, the distance from the release to the first pulley must be greater than the movement of the arm (B).

To crimp cables together, pass the two wires through a cable connector and crimp using a pair of crimp pliers part number STD66-100.

Lift the valve lever into the START/UP position and make sure that the lever pin is at the bottom of the elongated slot in the link. Use the spring/wire strainer to tension the cable.

NOTE: The close proximity of the flange to the body does not allow room for all bolt holes to be drilled through on the larger valves. The holes are therefore tapped M16 on 4" and 5" valves and M20 on the 6" valve.

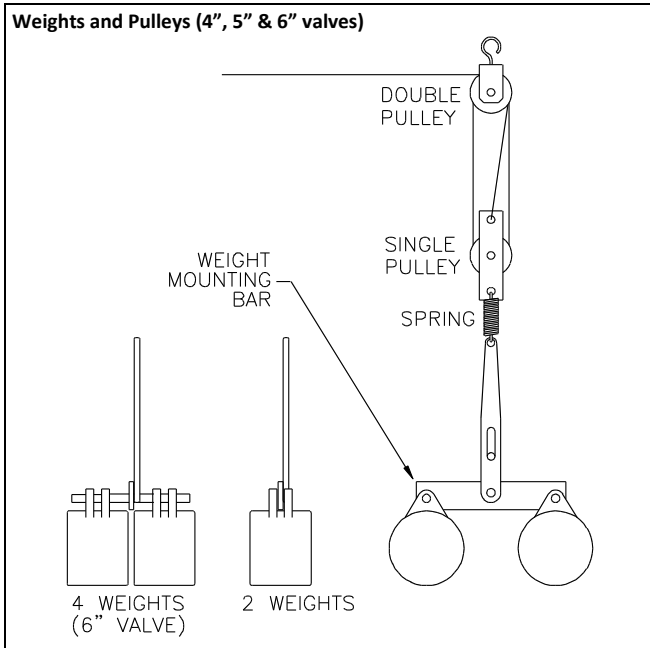

Standard Parts & Spares No. = Standard Quantity

1	Lever (sizes A to F depending on valve size)
1	Free-fall elongated slot link
9m	Cable - s/steel (30m, 150m, 300m, 760m available)
2	Brass M6 hooks with pulleys
1	M6 Hook
1	M6 Munsen Ring / Wall plate
1	Turnbuckle tensioner
1	Weight mounting bar (for valves ≥ 4")
5	Cable connectors (soft tube)
1	Tension Spring
1	Fusible link 72°C (std.), 92°C, 103°C, 128°C, 133°C, 145°C, 183°C available.
1	Warning notice to hang on cable
1	Double Pulleys (for 4", 5" & 6" valves)

TEST

Release the cable by releasing the quick release mechanism. The valve should close in a controlled manner with the lever travelling through a full 90°.

If the valve does not travel through the full 90° (¼ turn):

- Check for physical obstruction of the lever and weight(s). E.g. pipework
- Check the fusible link(s) and cable joins do not jam against pulleys
- Make sure that the cable is fitted around the pulleys and has not slipped off
- Lubricate the valve if stiff (see below)

LUBRICATION

If using a grease injection gun (10034501 & 10034521), connect to the grease nipple at the end of the lubricating screw. If lubricating by hand remove the lubricating screw from the end of the square shaft. Fill the reservoir inside the shaft with lubricant stick and replace the screw. Tighten the screw until a definite increase in resistance is felt, inserting further lubricant as necessary. 'Pump' the valve lever up and down several times to ensure the valve is free-moving.

If you have any questions or need any help then please contact our sales office.

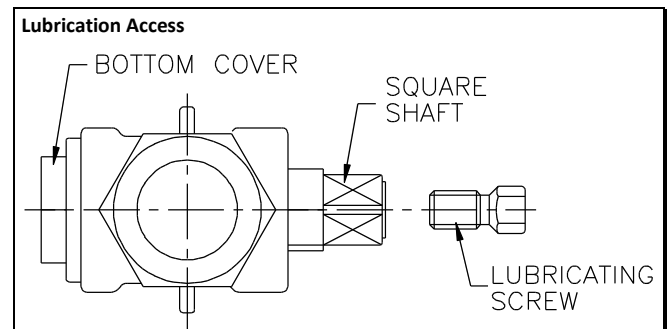

109037XX FREE FALL FIRE VALVE MKII

VALVE DESIGN FEATURES

- (1) 90° ROTATIONAL MECHANICAL STOP
- (2) SINGLE PIECE DIMENSIONALLY CONTROLLED PLUG AND BODY GAP CHEMICALLY SEALED UNDER PRESSURE PROVIDES NO SEEPAGE INTO THE MEDIA LINE EVEN AT 20BAR PRESSURE INJECTION
- (3) TOP PTFE BEARING SEAL DESIGN IMPROVES LOW FRICTION ROTATIONAL MOVEMENT
- (4) LEAKAGE PREVENTED BY SPRING LOADED NON-RETURN CHECK VALVE INCORPORATED INTO STEM
- (5) INJECTION NIPPLE APFLOW FOR INJECTION WITH INCORPORATED NON-RETURN CHECK VALVE
- (6) VALVE BONNET INCORPORATING METAL TO METAL SEALING PREVENTING LEAKAGE TO ATMOSPHERE
- (7) BOTTOM PTFE BEARING SEAL ENHANCES LOW FRICTION ROTATIONAL MOVEMENT
- (8) SPRING DISC FEATURE MINIMISES LOAD IMPRESSION ON PTFE BEARING REDUCING WEAR
- (9) COMPRESSION SPRING EXERTS 100% SPECIFIC FORCE TO PLUG PROVIDING LOW FRICTIONAL ROTATION

Description	Material
BODY	ASTM A126
PLUG	ASTM A126
STEM SEAL	PTFE
CHECK ASSY	ASTM A29, ASTM A689, ASTM SA283
NIP-ASSY	ASTM A29, ASTM A689, ASTM SA283
BONNET	ASTM A126
PTFE-DISC	PTFE
DISC	ASTM A1011 CSB
SPRING	ASTM A401
STOP	ASTM A36
WEIGHT	ASTM A29
LEVER	ASTM A29
SPRING	ASTM 302
LINK	ASTM A240
CABLE	ASTM A240
CONNECTOR	ASTM B221

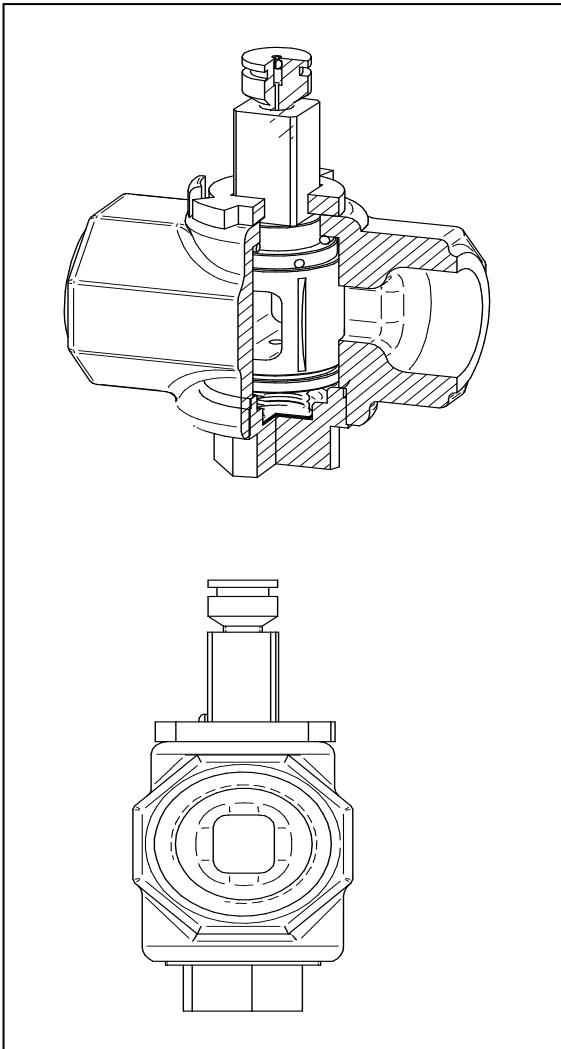

Maintenance:

The only maintenance required on lubricated plug valves is periodic re-lubrication (sealing) with valve sealant. Use only the plug valve sealant approved for the service.

The frequency of re-lubrication must be established for each specific service. As a general guideline, the valve should be re_lubricated as follows:

Number of Valve Cycles Maintenance Interval

1 - 30 Times Monthly

Less Frequently Three times Annually

Note: Intervals shown are approximate and may vary based on the specific flow media, temperature, pressure and age/condition of the valve. The intervals can best be determined by experience and can be lengthened or shortened according to each individual situation.

109037XX FREE FALL FIRE VALVE MKII

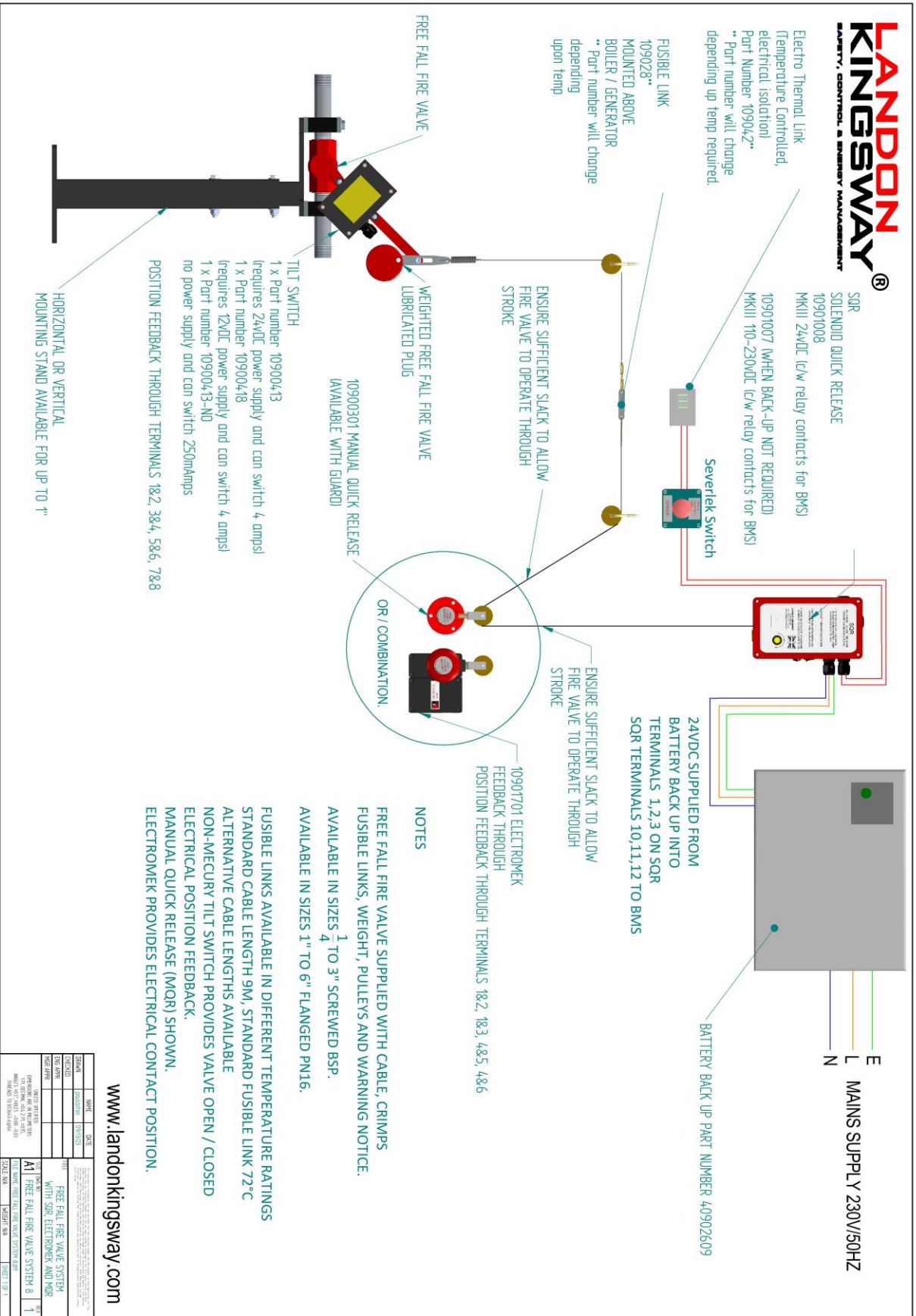

109037XX FREE FALL FIRE VALVE MKII

Flow Data

Part Number	SIZE DN - in	Kv	Cv
10903701H (Screwed)	15 - 1/2"	16	19
10903705H (Screwed)	20 - 3/4"	27	31
10903709H (Screwed)	25 - 1"	36	42
10903718H (Flanged)	25 - 1"	35	40
10903713H (Screwed)	32 - 1 1/4"	62	72
10903714H (Flanged)	32 - 1 1/4"	60	70
10903717H (Screwed)	40 - 1 1/2"	73	85
10903718H (Flanged)	40 - 1 1/2"	79	91
10903721H (Screwed)	50 - 2"	130	150
10903722H (Flanged)	50 - 2"	117	135
10903726H (Flanged)	65 - 2 1/2"	199	230
10903730H (Flanged)	80 - 3"	302	350
10903734H (Flanged)	100 - 4"	497	575
10903738H (Flanged)	125 - 5"	691	800
10903740H (Flanged)	150 - 6"	700	810

Kv is defined as flow in cubic meters per hour of water (temp 5 to 40 deg C) passing through the valve when pressure drop is 1 bar across the valve.

Cv is defined as the volume of water (Gallon per Minute in the United States) at 60°F that will flow through a fully open valve with a pressure differential of 1 psi across the valve