

HYDROSTATIC GAUGE

Surface mounting hydrostatic gauge for use with the Landon Kingsway range of hydrostatic sensors. The 160mm diameter gauge is suitable for mounting in the Landon Kingsway range of fillpoint cabinets.

The 100 and 160mm gauges are also available in panel-mounting versions.

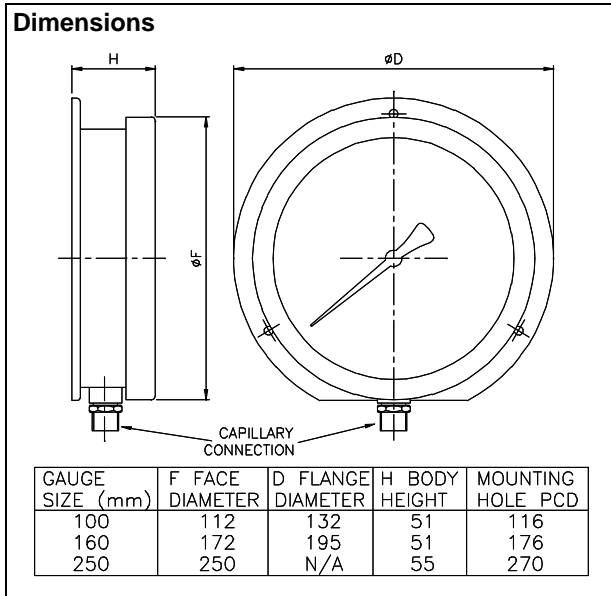

INSTALLATION

Unpack the gauge ensuring that the Red plastic cap is NOT disturbed as this would cause the loss of the Nitrogen gas inside the gauge.

Fix the gauge to a vertical surface using the three mounting holes, or if using the panel mounting version use the supplied clips to fit the gauge into a panel cutout.

For sensor installation see the sensor datasheet.

To attach the capillary, remove the caps from the gauge and sensor, **fit the supplied O-ring** and tighten up the nut using a 20mm spanner. **Do not over tighten.**

Technical Specification

Materials Stainless steel case, shatter, scratch resistant transparent window.
Dimensions See Diagram
Sizes Available 100, 160, 250mm
Scale Single/Dual Calibrated to requirements.
 Marking to M&E3 if reqd.

100mm Gauge
Mounting holes Ø4.8mm
Panel cutout version Ø100mm
Weight 0.8kg

160mm Gauge
Mounting holes Ø5.5mm
Panel cutout version Ø160mm
Weight 1.3kg

250mm Gauge
Mounting holes Ø6.0mm
Weight 1.6kg

IMPORTANT POINTS

- **Do NOT remove the cap from the capillary until ready to seal the system.**
- The end of the capillary **MUST** be kept clean and dry until the system is sealed.
- **Do NOT remove the end caps until**

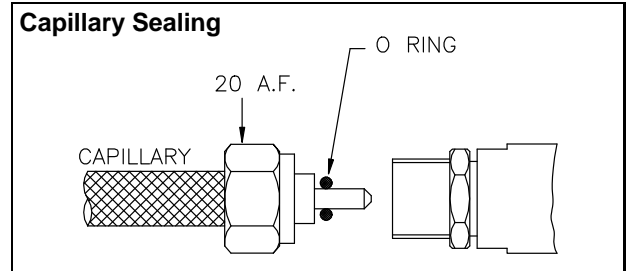

ready to seal the system.

If you have any questions or need any help then please contact our sales office.

Failure to follow these installation instructions will result in the warranty becoming void.