

TANK CONTENT GAUGE SERIES- TCG



TCG Gauge

Internal Sensor

External Sensor

The Landon Kingsway TCG series calibrated hydrostatic tank contents gauge featuring capsule type movement for remote contents indication up to 30m. Individually calibrated to suit tank heights of between 600mm and 10m height or diameter depending on the density of the liquid to be measured.

Technical Specification

Materials	Stainless steel case, shatter, scratch resistant transparent window.
Scale	Single/Dual Calibrated to requirements. Marking to M&E3 if reqd.
160mm Gauge	
Mounting holes	Ø5.5mm
Panel cutout version	Ø160mm
Weight	2.7kg
Sensor Material	Mild steel with Viton diaphragm. Also available in stainless steel.
Dimensions	Ø130mm x 40mm sensor
Mounting Connection	¾" BSP
Max Capillary length	100m to gauge.

Dimensions

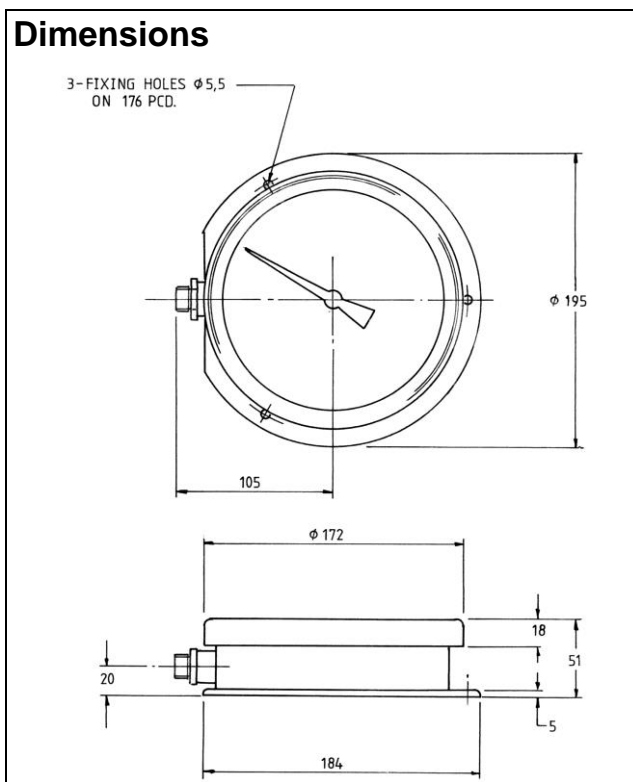

The Landon Kingsway Tank Contents Gauge TCG Series are manufactured and calibrated to each individual oil storage tank to ensure the system can maintain high accuracy and a long service life.

The Landon Kingsway Tank Contents Gauge TCG are manufactured from stainless steel and are of the highest quality.

The standard system will comprise of three components, the hydrostatic tank sensor, capillary tube and the hydrostatic contents level gauge. 4-20mA transducers and relay switches can be incorporated to allow full BMS system integration.

Note: These gauges are made to order, we will contact you regarding the tank details after purchase.

TANK CONTENT GAUGE SERIES- TCG

INSTALLATION

The Landon Kingsway Tank Contents Gauge TCG houses a precision movement and metallic capsule, which has been carefully calibrated to suit each individual tank specification. It should be positioned with care so that is protected from mechanical damage by plant or other machinery. Although the Indicator is weatherproof, we recommend that it be positioned, wherever possible, in an area that is not fully open to the elements.

The tank gauging system comprises of three parts, the sensor, capillary tube and the indicator. It is important not to allow any type of foreign matter, dirt or liquid to enter the small-bore capillary tube which may result in blockage and lead to inaccurate readings or failure of the gauge.

It is important to remember that the sensor should **NOT** be fitted to / into the tank prior to the capillary being connected. If it is connected this will give false or inaccurate readings or may fail to work.

Once the capillary tube has been routed loosely along its path, the sensor placed at the storage vessel and the indicator where it is to be mounted, push it onto the gauge and sensor fitting and tighten the knurled nut by hand.

With the capillary tube now fitted to the indicator or sensor to make the system a sealed unit, the sensor can now be fitted to the storage vessel and the indicator fitted in its permanent position. Finally, the capillary tube can be fixed along its preferred route for which is it recommended that plastic cable ties be used.

INTERNAL TANK SENSOR FITTING

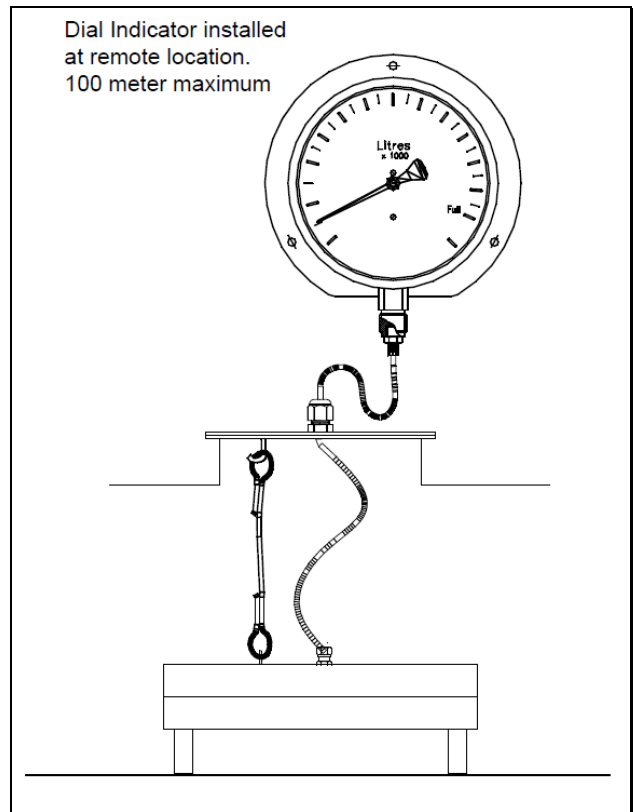

The Landon Kingsway Tank Contents Gauge TCG (Internal) sensor is an internally mounted hydrostatic sensor which is suspended from the top the tank. The sensor should be fitted 100mm from base of tank. Installation procedure is the same as External tank sensor i.e. capillary should be connected to Gauge and sensor prior to suspending into the tank, lower the sensor by the lifting cable / wire rope not by the capillary / tube. If for any reason the tube has to be disconnected from the gauge the sensor should be removed from the tank, this ensures that the diaphragm does not collapse. If the airbag within the sensor collapses in either internal or external tank sensor it can be re-inflated with 2psi air.

TANK CONTENT GAUGE SERIES- TCG

External Tank Sensor fitting

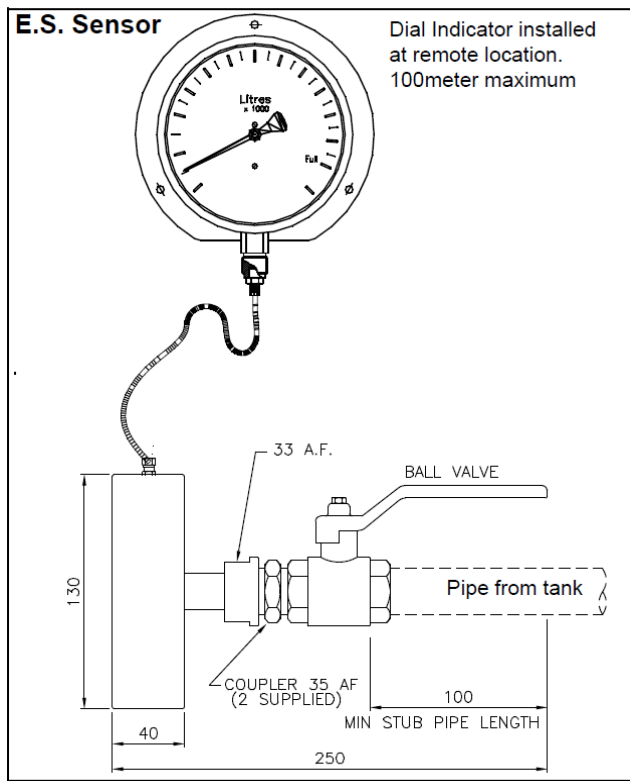

The E.S. (External) sensor is an externally mounted hydrostatic sensor which is attached at the base of the tank being measured (above the sludge level) via a $\frac{3}{4}$ " BSP stub pipe. A ball valve and two male-male couplers are required to allow isolation of the sensor. This makes the installation very straightforward. Please contact sales for ball associated ball valve and couplers.

In order to fit the sensor the tank MUST be completely empty of liquid so the ball valve can be fitted onto the stub pipe. Note that the stub pipe should be sufficiently long so that the lever of the ball valve is not obstructed (see diagram above).

The calibration of the instrument will not be affected by the elevation of the indicator in relation the tank sensor, it is important to remember that the gauge has been calibrated from a set datum point that was quoted at the time of order (i.e. sensor distance above tank base).

Where sensors are mounted below the storage vessel the calibration will include any offset based upon the data received at the time of order.

MAINTENANCE

The Landon Kingsway Tank Contents Gauge TCG should be checked annually for component condition and correct reading, the gauge reading can be checked by dipping the tank with an accurate dipstock or if not against a known delivered amount.

Part Number	Description
3116088	TCG-1 Tank Contents Gauge 160mm M/S Ext Sensor 30m Viton Diaphragm 0-2m Tanks
3126088	TCG-2 Tank Contents Gauge 160mm M/S Ext Sensor 30m St.St Diaphragm >2m Tanks
3136088	TCG-3 Tank Contents Gauge 160mm S/S Ext Sensor 30m Viton Diaphragm 0-2m Tanks
3146088	TCG-4 Tank Contents Gauge 160mm S/S Ext Sensor 30m St.St Diaphragm >2m Tanks
3156088	TCG-5 Tank Contents Gauge 160mm M/S Suspended Sensor 30m Viton Diaphragm 0-2m Tanks
3166088	TCG-6 Tank Contents Gauge 160mm M/S Suspended Sensor 30m St.St Diaphragm >2m Tanks
3176088	TCG-7 Tank Contents Gauge 160mm S/S Suspended Sensor 30m Viton Diaphragm 0-2m Tanks
3186088	TCG-8 Tank Contents Gauge 160mm S/S Suspended Sensor 30m St.St Diaphragm >2m Tanks